



Alpha Sentra XL Battery Pack

User Manual

Document #: 0320000-J0

Effective 04/2012

Alpha Sentra XL Battery Pack

NOTE:

Photographs contained in this manual are for illustrative purposes only. These photographs may not match your installation.

NOTE:

Operator is cautioned to review the drawings and illustrations contained in this manual before proceeding. If there are questions regarding the safe operation of this powering system, contact Alpha Technologies or your nearest Alpha representative.

NOTE:

Alpha shall not be held liable for any damage or injury involving its enclosures, power supplies, generators, batteries, or other hardware if used or operated in any manner or subject to any condition inconsistent with its intended purpose, or if installed or operated in an unapproved manner, or improperly maintained.

For technical support, contact Alpha Technologies:

Canada and USA: 1-888-462-7487

International: +1-604-436-5547

Email: support@alpha.ca

Copyright

Copyright © 2012 Alpha Technologies Ltd. All rights reserved. Alpha is a registered trademark of Alpha Technologies.

No part of this documentation shall be reproduced, stored in a retrieval system, translated, transcribed, or transmitted in any form or by any means manual, electric, electronic, electromechanical, chemical, optical, or otherwise without prior explicit written permission from Alpha Technologies.

This document, the software it describes, and the information and know-how they contain constitute the proprietary, confidential and valuable trade secret information of Alpha Technologies, and may not be used for any unauthorized purpose, or disclosed to others without the prior written permission of Alpha Technologies.

The material contained in this document is for information only and is subject to change without notice. While reasonable efforts have been made in the preparation of this document to assure its accuracy, Alpha Technologies assumes no liability resulting from errors or omissions in this document, or from the use of the information contained herein. Alpha Technologies reserves the right to make changes in the product design without reservation and without notification to its users.

Contents

| | | |
|--------|--|----|
| 1. | Important Safety Instructions | 1 |
| 2. | Introduction to the Front and Rear Panel | 3 |
| 2.1. | Front and Rear Panel Descriptions | 3 |
| 3. | Installation and Operation..... | 4 |
| 3.1. | Unpacking | 4 |
| 3.2. | Selecting Installation Position..... | 5 |
| 3.2.1. | Tower Installation – Standalone Unit | 6 |
| 3.2.2. | Tower Installation – Combined with UPS | 7 |
| 3.2.3. | Rack Mount installation | 8 |
| 3.2.4. | Connect DC Cable..... | 10 |
| 3.2.5. | Storage Instruction..... | 10 |
| 3.2.6. | Replacing the Battery..... | 11 |
| 3.3. | Specification | 12 |
| 3.4. | Recycling the Used Battery | 12 |

1. Important Safety Instructions

Save These Instructions

This section contains important instructions that must be followed during the installation and maintenance of the equipment and batteries. Read all of the instructions before operating the equipment, and save this manual for future reference.

The following safety symbol is found throughout this manual:



Carefully read all information and abide by the instructions.

The following warning levels are used in conjunction with the symbol:

DANGER: You WILL be KILLED or SERIOUSLY INJURED if instructions are not followed closely.

WARNING: You CAN be KILLED or SERIOUSLY INJURED if instructions are not followed closely.

CAUTION: You CAN be INJURED or equipment can be DAMAGED if instructions are not followed closely.

Battery Safety

Servicing and connection of batteries must be performed by, or under the direct supervision of, trained personnel knowledgeable of batteries and the required safety precautions.



CAUTION: Follow battery manufacturer's safety recommendations when working around battery systems.



CAUTION: Batteries are hazardous to the environment and should be disposed of safely at a recycling facility. Consult the battery manufacturer for recommended local authorized recyclers.



CAUTION: Do Not Dispose of Battery or Batteries in an open fire. The battery may explode.



CAUTION: Do not open or mutilate the batteries. The electrolyte from the batteries is toxic and harmful to the skin and eyes.



CAUTION: Risk of Electric Shock – the battery circuit is not isolated from AC, a hazardous voltage may exist between battery terminals and ground. Test before touching with bare hands.



CAUTION: A Battery can present a risk of electrical shock and high short circuit current. Observe the following precautions when working on batteries:

- Remove watches, rings, or other metal objects.
- Use tools with insulated handles.
- Wear rubber gloves and boots.
- Do not lay tools or metal parts on top of batteries.
- Disconnect charging source prior to connecting or disconnecting battery terminals.

- This battery pack is intended to be connected to an UPS. There will be a DC voltage at the connector terminals.
- Do not try to repair the unit yourself, contact your local supplier or your warranty will be void.
- To eliminate any overheating of the battery pack, keep all ventilation openings free from obstruction and do not place any foreign objects on top of the battery pack. Keep the battery pack 20 cm (8 in) away from the wall.
- Make sure the battery pack is installed within the proper environment as specified – ambient 0-40°C (32-104°F) and 30-90% non-condensing humidity.
- Do not install the battery pack under direct sunlight. Your warranty will be void if the batteries fail due to overheating.
- This battery pack is designed for indoor use only.
- This battery pack is not designed for use in dusty, corrosive and salty environment.
- The warranty for this battery pack will be void if water or other liquid is spilt or poured directly onto the battery pack. Similarly we do not warrant any damage to the battery pack if foreign objects are deliberately or accidentally inserted into the battery pack enclosure.
- The battery will discharge naturally if the system is unused for a period of time. It should be recharged every two to three months if unused. If this is not done, then the warranty will be null and void.
- During normal operation, the batteries will be automatically remained in charged condition.
- When replacing batteries, always replace with the same quantity, type and capacity.

2. Introduction to the Front and Rear Panel

2.1. Front and Rear Panel Descriptions

| | | |
|---|--------------|---|
| 1 | Front Cover | To replace batteries, remove the front covers and the screws inside the covers. |
| 2 | EXT.BAT. +/- | To the DC terminal of the 2nd(or next) connected battery pack |
| 3 | UPS BAT. +/- | To the UPS DC terminal or the next battery pack. |

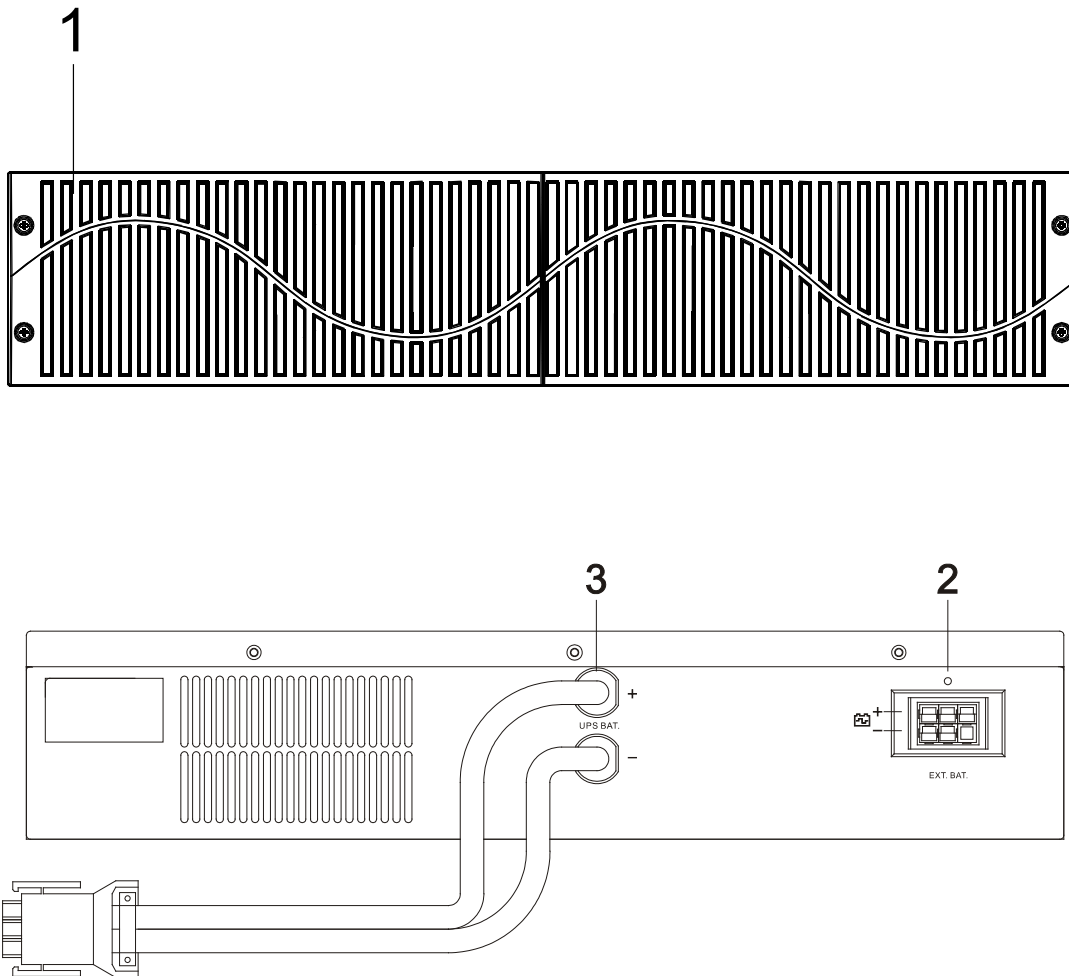

3. Installation and Operation

Note: The packing condition and the external outlook of the unit should be inspected carefully before installation. Retain the packing material for future use.

3.1. Unpacking

1. Take the battery pack out of the foam.
2. Remove the packing materials.



WARNING: The battery pack module is approximately 32 to 36 kgs (70 to 80 lbs); be cautious when unpacking and lifting the unit to avoid injury.

A standard package includes the following:

- User manual
- Accessories shown below for tower and rack mount

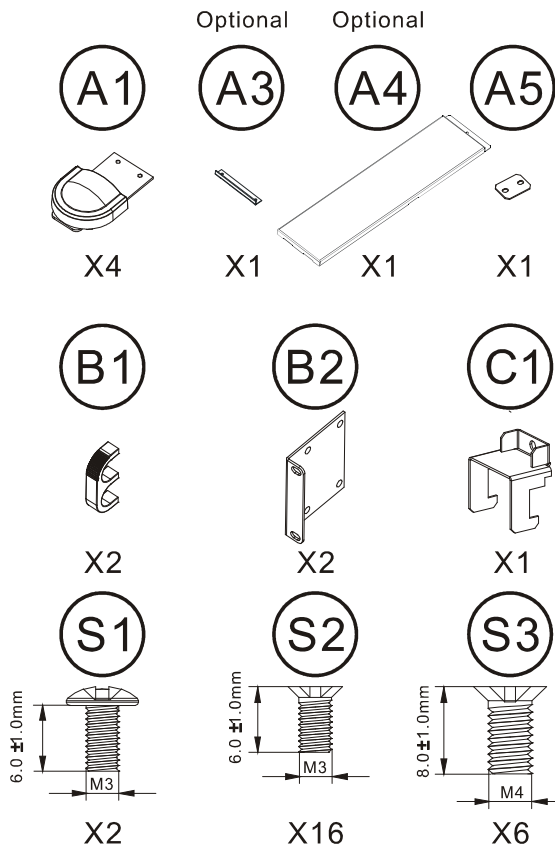

3.2. Selecting Installation Position

The battery cable is provided with an 8 inch cable. Plan to install the battery pack within 3 to 4 inches from the UPS or another battery pack.

It is necessary to select a proper environment to install the unit, in order to minimize the possibility of damage to the battery pack and extend the life of the batteries. Please follow the instructions below:

1. Keep at least 20cm (8 inches) clearance from the rear panel of the battery pack from the wall or other obstructions.
2. Do not block the air-flow to the ventilation openings of the unit.
3. Please ensure the installation site environmental conditions are in accordance with the battery pack working specifications to avoid overheat and excessive moisture.
4. Do not place the battery pack in a dusty or corrosive environment or near any flammable objects.
5. This battery pack is not designed for outdoor use.

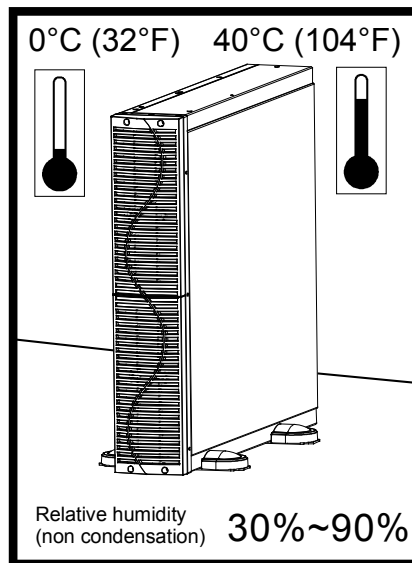
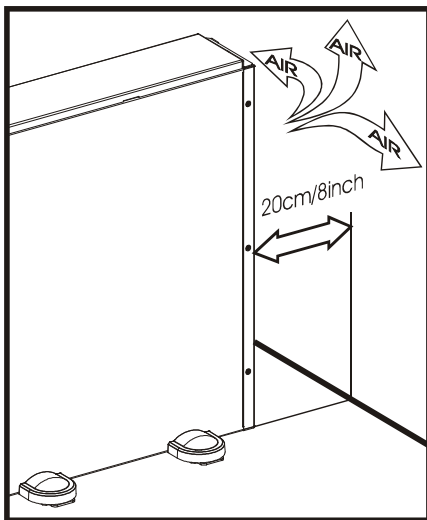

3.2.1. Tower Installation – Standalone Unit

STEP 1

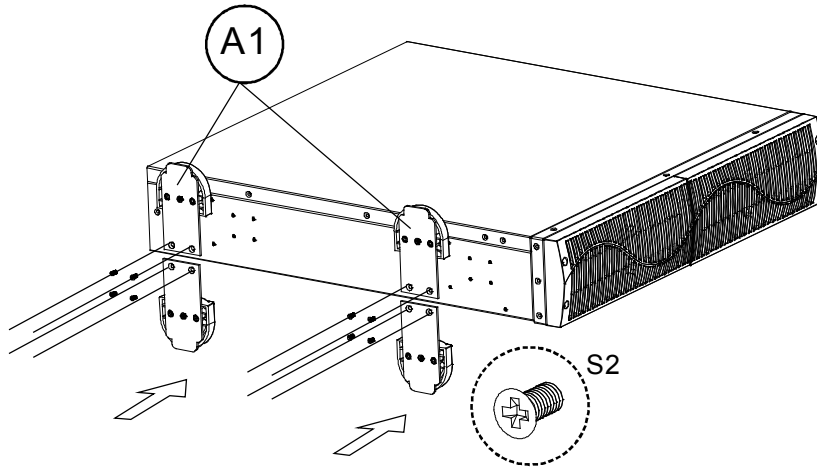

STEP 2

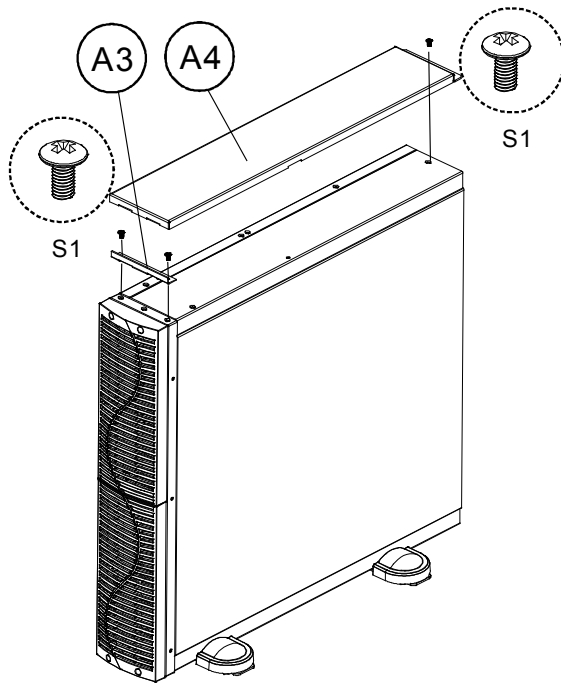

3.2.2. Tower Installation – Combined with UPS

STEP 1

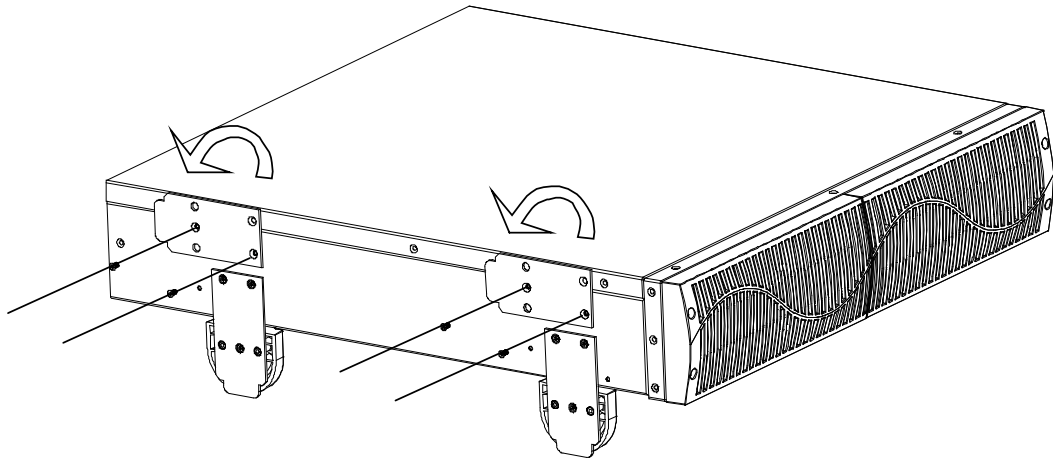

STEP 2

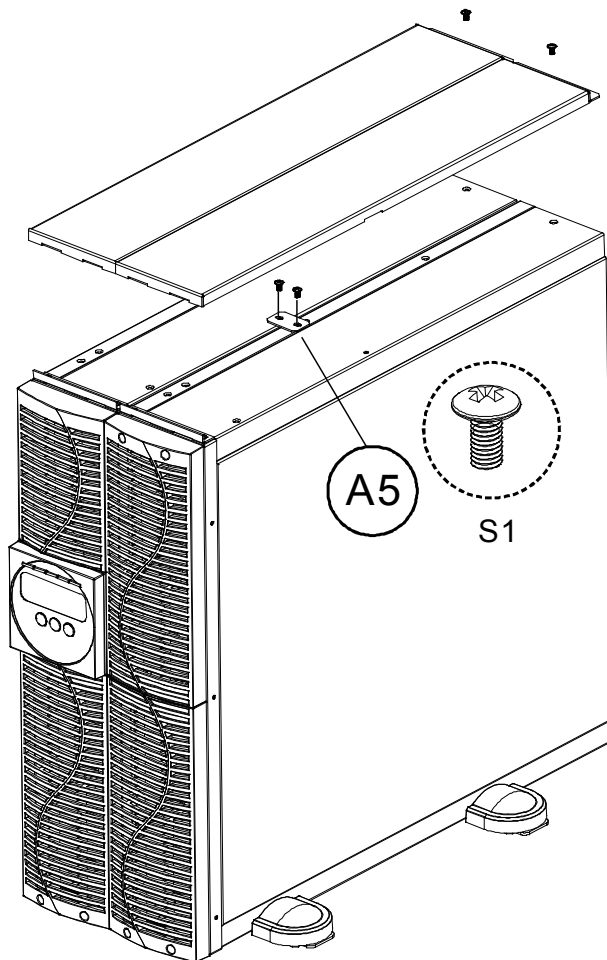

3.2.3. Rack Mount installation

STEP 1

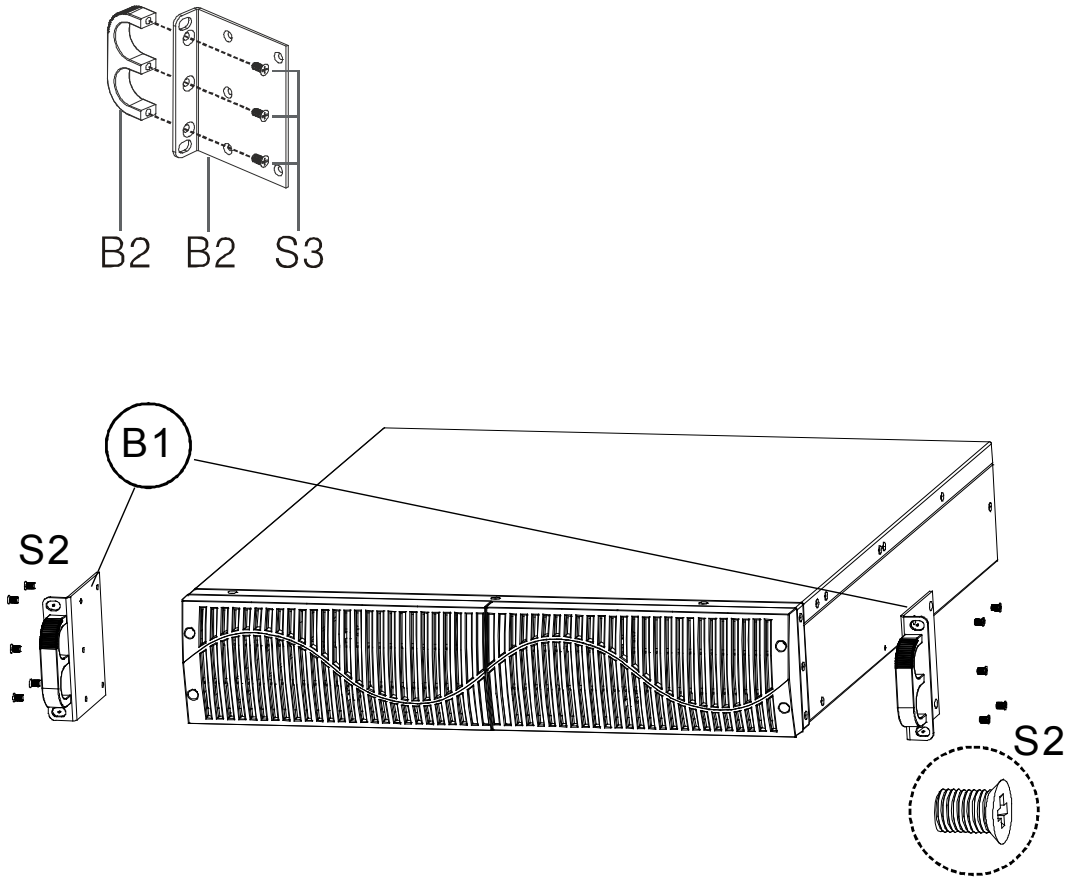

STEP 2

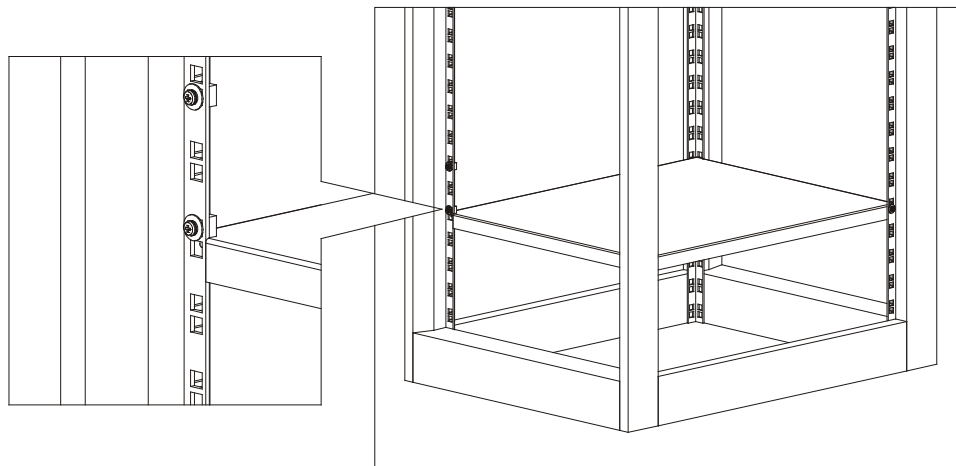

STEP 3

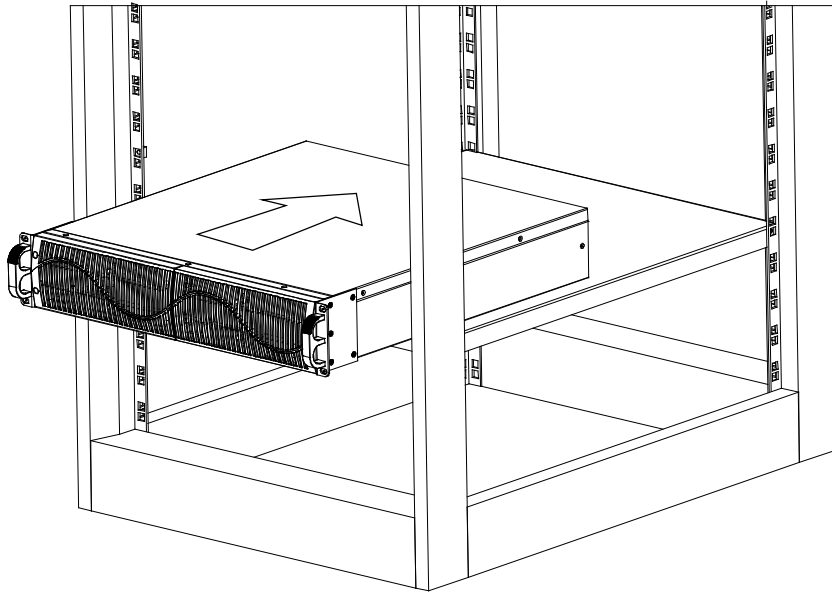

STEP 4

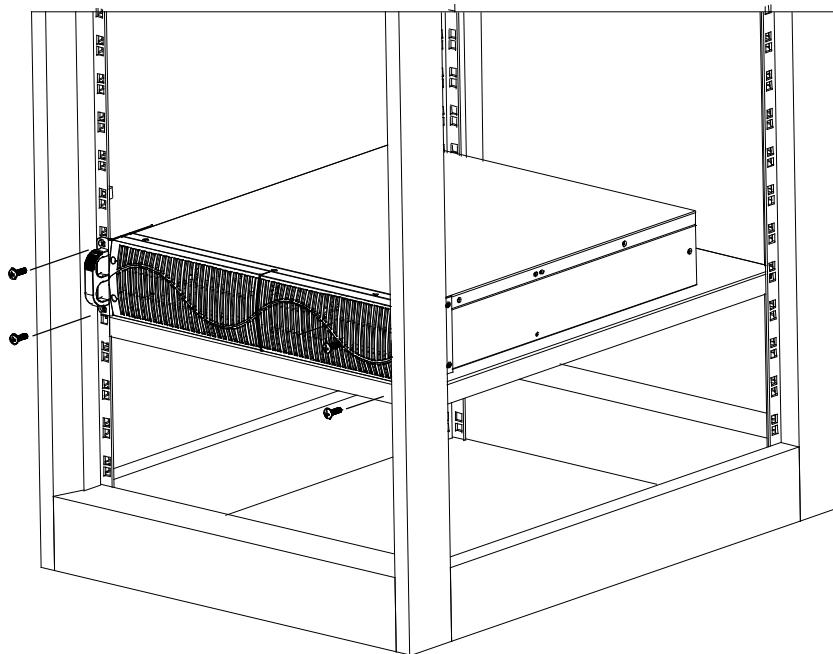

3.2.4. Connect DC Cable

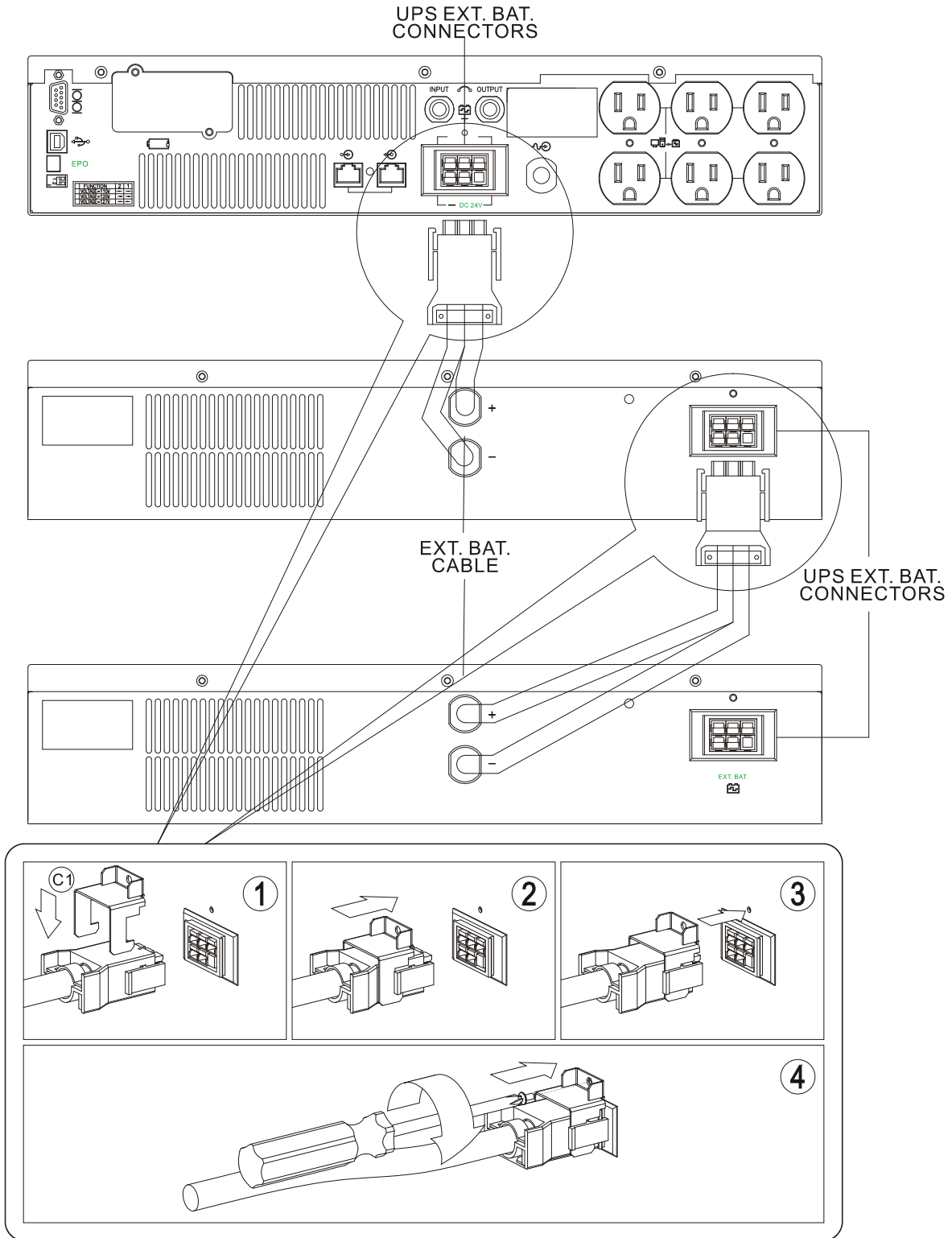

3.2.5. Storage Instruction

For extended storage in a moderate climate (-5 to +30 °C / 23 to +86 °F), the batteries should be charged for 12 hours every 6 months by plugging in to a UPS. Repeat this every 3 months at higher temperatures (+30 to +45 °C / +86 to +113 °F). Do not store batteries under conditions that are outside of this range.

3.2.6. Replacing the Battery

STEP 1

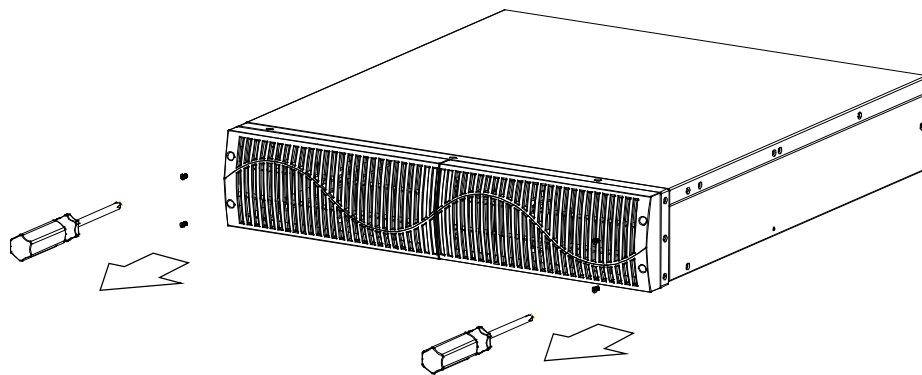

STEP 2

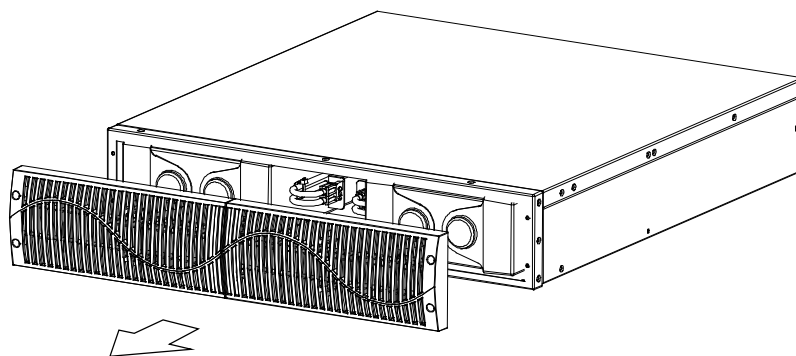

STEP 3

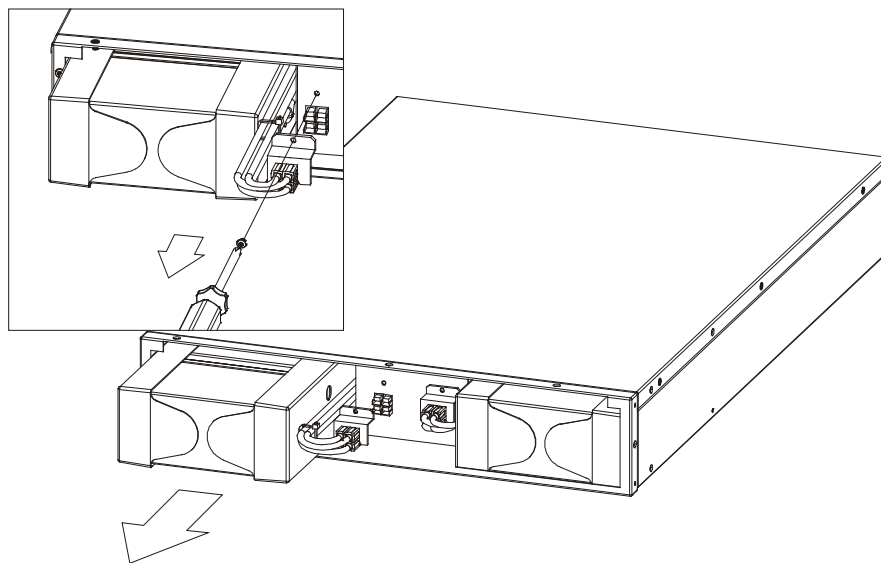

3.3. Specification

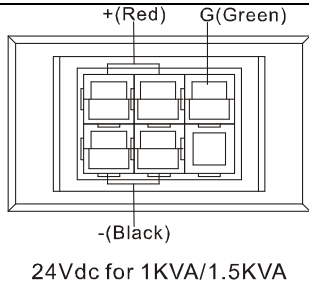
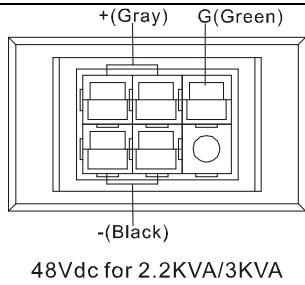
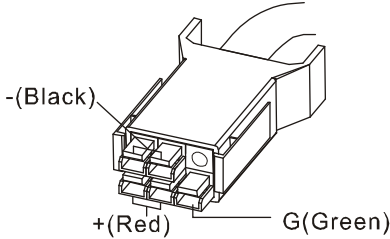
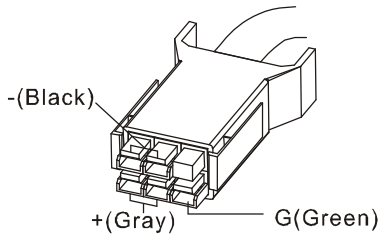
| UPS | 1000VA | 1500VA | 2200VA | 3000VA |
|--------------------------|--|-------------------|---|-------------------|
| Battery Pack Model | BP Sentra XL 1000 | BP Sentra XL 1500 | BP Sentra XL 2200 | BP Sentra XL 3000 |
| Part Number | 0320000-001 | 0320001-001 | 0320002-001 | 0320003-001 |
| Nominal System Voltage | 24VDC | 24VDC | 48VDC | 48VDC |
| Battery Quantity | 8 | 8 | 8 | 8 |
| Battery Type | 7Ah | 9Ah | 7Ah | 9Ah |
| Max. Charge Current | 8.4A | 10.8A | 4.2A | 5.4A |
| Connector color | Red (+) , Black (-) | | Gray (+) , Black (-) | |
| DC Sockets Diagram |  <p>24Vdc for 1KVA/1.5KVA</p> | |  <p>48Vdc for 2.2KVA/3KVA</p> | |
| DC Plug Diagram |  | |  | |
| Dimensions W x D x H, mm | | | | |
| Unit | 440 x 482 x 88 | | | |
| Shipping | 560 x 675 x 228 | | | |
| Weight, kg | | | | |
| Unit | 29 | 33.4 | 29 | 33.4 |
| Shipping | 32 | 36.4 | 32 | 36.4 |

3.4. Recycling the Used Battery



Contact your local recycling or hazardous waste center for information on proper disposal of the used battery

**Alpha Technologies Ltd.**

7700 Riverfront Gate
Burnaby, BC V5J 5M4
Canada
Tel: +1 604 436 5900
Fax: +1 604 436 1233
Toll Free: +1 800 667 8743

Alpha Technologies Inc.

3767 Alpha Way
Bellingham, WA 98226
United States
Tel: +1 360 647 2360
Fax: +1 360 671 4936

Alpha Industrial Power Inc.

1075 Satellite Blvd NW,
Suite 400
Suwanee, GA 30024
United States
Tel: +1 678 475 3995
Fax: +1 678 584 9259

Alpha Energy

1628 W Williams Drive
Phoenix, AZ 85027
United States
Tel: +1 602 997 1007
Fax: +1 623 249 7833

Alpha Technologies GmbH

Hansastraße 8
D-91126
Schwabach, Germany
Tel: +49 9122 79889 0
Fax: +49 9122 79889 21

**Technologies Argus
First de Mexico**

Anatole France Num. 17
Colonia Polanco
11560, México D.F.
Tel: +52 55 5280 6990

Alpha Technologies Europe Ltd.

Twyford House Thorley
Bishop's Stortford
Hertfordshire, CM22 7PA
United Kingdom
Tel: +44 1279 501110
Fax: +44 1279 659870

Alphatec Ltd.

339 St. Andrews St.
Suite 101 Andrea Chambers
P.O. Box 56468
3307 Limassol, Cyprus
Tel: +357 25 375 675
Fax: +357 25 359 595

Alpha TEK ooo

Khokhlovskiy Pereulok 16
Stroenie 1, Office 403
Moscow, 109028
Russia
Tel: +7 495 916 1854
Fax: +7 495 916 1349

Alpha Technologies

Unit 504, 5/F,
Fourseas Building
No 208-212 Nathan Road
Kowloon, Hong Kong
Tel: +852 2736 8663
Fax: +852 2199 7988

Alpha Innovations Brasil

Rua Manuel Augusto
de Alvarenga, 155,
São Paulo, SP - Brasil
Tel: +55 11 2476 0150
Fax: +55 11 2476 0150

Alphatec Baltic

S. Konarskio Street 49-201
Vilnius, LT-03123
Lithuania
Tel: +370 5 210 5291
Fax: +370 5 210 5292

Visit us at www.alpha.ca

Power